

Chapter-1

Introduction

1.1 Right to Information Act, 2009.

An act to provide for setting out the regime of right to information for the people of the State to secure access to information under the control of Public Authority, in order to promote transparency and accountability in the working of every public authority.

1.2 Objective/purpose of this handbook.

The objective/purpose of this hand book prepared under the J&K Right to Information Act, 2009 is to keep the public informed about the Division/Organisation, its functions, duties etc and to facilities the public at large regarding the procedure etc for seeking information pertaining to the Civil Division-I JKSPDC Kargil

1.3. Who can use this handbook.

Any person can use this handbook, as the same has been prepared for the information of the public at large under the J&K RTI Act. 2009.

1.4 Organisation of the information in this handbook?

Civil Division-I JKSPDC Kargil.

1.5 Definitions (Please provide definitions of various terms used in the handbook).

JKSPDC: Jammu and Kashmir Power Development Corporation.

HEP: Hydro Electric Project.

MW: Mega Watt.

1.6 Contact Person.

Chief Project Engineer Ladakh Region Kargil
Phone No: 01985-232240.

Executive Engineer Civil Division-I PDC Kargil.

Phone No: 01985- 232276.

1.7 Procedure and Free Structure for getting information.

A request for obtaining information shall be accompanied by an application fee of Rupees fifty by way of cash against proper receipt or by India Postal Order or demand draft or bankers cheque payable to the Accounts Officer of the Public Authority.

A request for obtaining information shall be deemed to be made duly accompanied by prescribed application fee if it is written on a non-judicial stamp paper of Rupees fifty. Particulars of Organization

Chapter-2

PARTICULAR OF ORGANIZATION, FUNCTIONS AND DUTIES.

2.1 Objective/purpose of the public authority.

Power Development Corporation J&K had established two divisions in Kargil District, one has been named as Civil Division-I and other one as Civil Investigation Division Kargil. The main function of civil investigation division was to conduct survey and submit feasibility report for constructing Hydro Electric Projects while as the function of civil division-I is to prepare estimates and to putting the work to tender and over all supervision and complication of work.

2.2 Mission/vision statement of the public authority.

Vision statement:- To explore possibility of identifying power projects in Ladakh Region especially in Kargil District so that power could be generated for supply to general public and others round the clock. The villages are scattered in a very huge area and being a hilly area there is minimum forest and people have to face huge shortage of fire wood for domestic purpose. The main aim of corporation is to explore possibility of constructing power projects so that electricity could be provided to public on cheaper rate.

2.3 Brief history of the public authority.

Since its establishment in Kargil district in 1981 this division has identified many HEP's on different rivers/ nallahs and most of them has been completed.

2.4 Duties of the public authority

The duties of the Institute involve functioning as:

The duties of divisions are to investigate/conduct survey of various river/nallah and to submit information to corporate office at Srinagar/Jammu for approval and after getting approval for framing of estimate and implementation of work on ground and its supervision.

2.5 List of services being provided by the public authority with a brief write ups on them.

The following HEP's have been completed since its establishment.

1. Iqbal Mini Hydel Project Kargil (IMHP) 3.75 MW.

This project has been started in 1986 and completed/ commissioned in 1995 and is supplying electricity to Kargil town and its adjoining area.

2. Marpochoo Hydro Electric Project Drass (HEP Marpochoo) 0.75 MW.

HEP Marpochoo was started in 1989 and completed in 2003 and since then supplying power to Drass area during summer. Being Drass area is most coldest place the project remain under shut down from December to March every year.

3. Hydro Electric Project Sanjak (HEP Sanjak) 1.26MW

This project stands constructed on Kanji Nallah and has been started in 1989 and completed on 2011 and since then supplying power to Sanjak and adjoining area during summer period and is also remain under shut down from Nov. to April every year due to freezing of water in Kanji Nallah.

4. Hydro Electric Project Haftal Zanskar. (HEP Zanskar) 0.50MW.

The Project stands constructed at Sani Zanskar by tapping Haftal Nallah and is supplying power to Padum and adjoining area during summer period only and is also remain under shutdown during winter period due to freezing of Nallah water.

2.7 Organisational chart of Power Development Corporation Kargil.

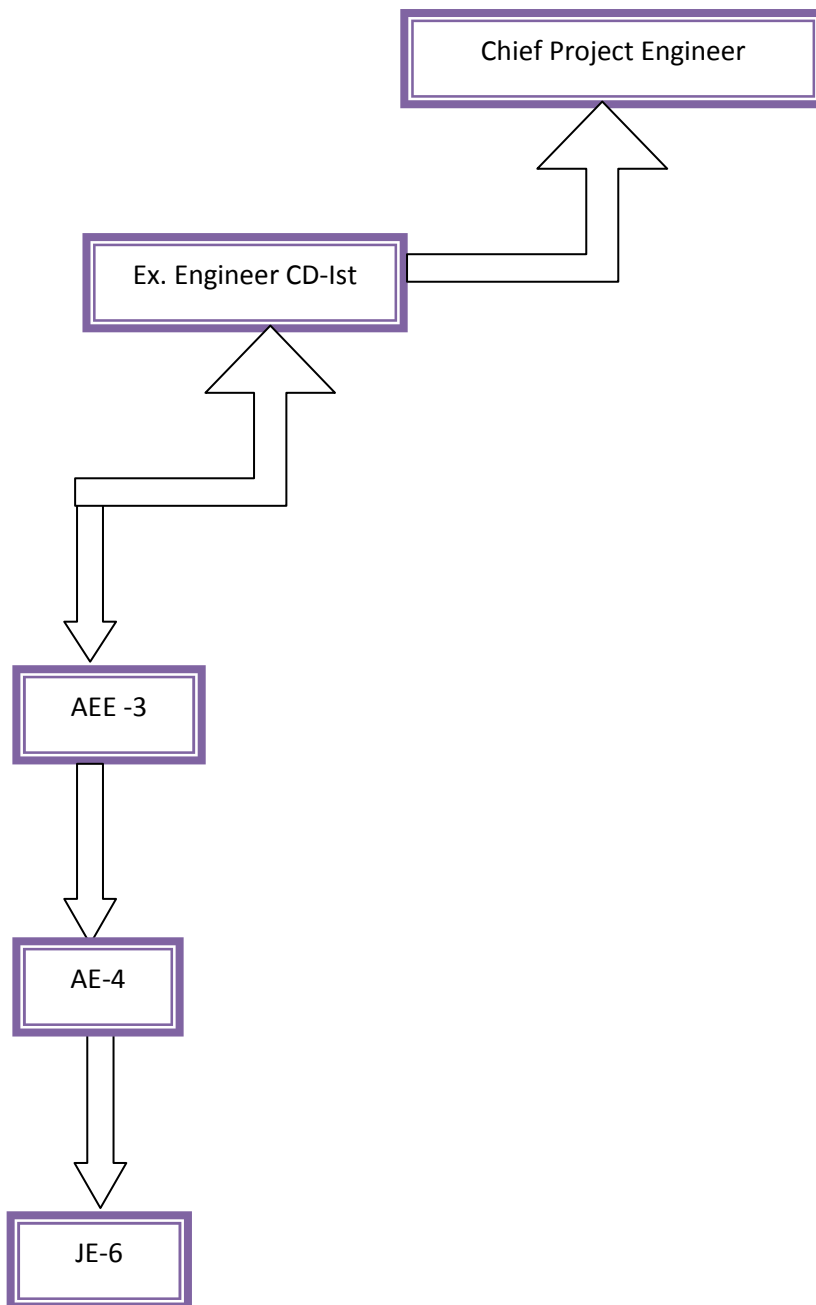

2.8 Expectation of the public authority from the public for Enhancing its effectiveness and efficiency.

To the general public is expected to send their feed back about the projects run by the department.

2.9 Arrangements and methods made for seeking public/ contribution.

The general public can submit their complaints to divisional office.

2.10 Mechanism available for monitoring the service delivery and public grievance resolution.

Any specific information/grievance related to work may be addressed after approval by Corporate Office J&K Power Development Corporation Srinagar/Jammu.

2.11 Addresses of the main office and other offices at different levels.

Main Office: Office of Managing Director JKSPDC Hotel Shah Inn Boulevard Srinagar.

Office of Chief Project Engineer PDC Ladakh Region Baroo Kargil.

Executive Engineer Civil Division-I and II PDC Baroo Kargil.

Closing hours of Offices 4.00PM (Six days a week)

Chapter-3

Power and duties of officers and employees.

3.1 Please provide details of the powers and duties of officers and employees of the organization.

Chief Project Engineer Ladakh Region PDC Kargil.

Administrative Power:-

He is the head of organization for Ladakh Region.

Financial powers:-

To accord approval of works.

Duties:-

He is over all incharge of projects and to monitor the progress of division and works on ongoing /completed projects and also to take review meeting to check the progress in field.

Executive Engineer Civil Division-I.

Administrative Power:-

Establishment and administration head of division.
Over all control of CD-Ist.

Duties:

To identify new project

To submit PFR to higher authorities.

To frame works programme.

To implement and executive of approved works.

Maintenance of ongoing projects.

Supervision and moniting of the quality of works.

Preparation of audit report and accounts.

Chapter-4

Rules, Regulations, Instructions, Manual and Records, for Discharging Functions.

That all the function are discharged by the officers employees in accordance with existing law, Rules, Regulation, Power Policies and other local law of land.

Chapter-5

Particulars of any arrangement that exists for consultation with, or representation by, the members of the public in relation to the formulation of its policy or implementation thereof.

Formulation of Policy:

Being a department of PDC, the policies are framed at head office.

Implementation of Policy:

Whether there is any provision to seek consultation/participation of public or its representatives for implementations of policies? If there is please provide details of the provision in following format.

S. No	Subject/Topic	Is it mandatory to ensure public participation	Arrangement for seeking public participation
01	For formulation of plans/ investigation of projects.	-	-

Chapter-6

A statement of the categories of documents that are held by it or under its control.

- 6.1 Use the format given below to give the information about the official document. Also mention the place where the documents are available for e.g. at secretariat level, directorate level, others (please mention the level in place of writing others).**

S. No	Category of the document	Name of the document and its introduction in one line.	Procedure to obtain the document	Held by/ under control of .
01	Pre-feasibility report.	PFR.	-	Xen
02	AA Project copy.	AA	-	Xen.

Chapter-9

Procedure followed in Decision Making Process.

- 9.1 What is the procedure followed to take a decision for various matters? (A reference to Secretariat Manual and Rule of Business Manual, and other rules/regulations etc can be made).**

As per the manual on office procedure.

- 9.2 What are the documented procedures/ laid down procedures/Defined Criteria/Rules to arrive at a particular decision for important matters? What are different levels through which a decision process moves.**

After conducting filed survey the projects are submitted to corporate office for approval.

- 9.3 What are the arrangements made to communicate the decision to the public.**

Through information department and through radio broadcasts.

- 9.4 Who are the officers at various levels whose opinions are sought for the process of decision-making?**

Chief Project Engineer PDC Ladakh Region and Managing Director JKSPDC Srinagar.

- 9.5 Who is the final authority that vets the decision?**

Managing Director JKS PDC Srinagar.

Chapter-13

The Manner of Execution of Subsidy Programmes

No such programme run by the division.

Chapter-14

Particulars of Recipients of Concessions, Permits or authorization granted by it.

No concessions, permits or authorization granted by the department.

Chapter-15

Norms set by it for the discharge of its function.

15.1 Please provide the details of the Norms/Standards set by the department for the execution of various activities/programmes.

The works are executed as per the allotment of funds approved by appropriate authorities.

Chapter-16

Information available in an electronic form.

16.1. Please provide the details of the information related to the various schemes which are available in the electronic format.

The website shall be launched and all related information will be uploaded.

Chapter-17

Particulars of the facilities available to citizens for obtaining information .

17.1 Means, methods or facilitation available to the public which are adopted by the department for dissemination of information.

Office library: There is no office library.

Drawn & shows nil.

Through new paper:- The department plan tender notices through newspaper

Exhibition: No such programme.

Inspection of records in the office:- No such system in office system of issuing copies of documents: Can be copied.

Printed Manual Available: No manual available.

Website of the Public Authoring: Not hosted yet.

Chapter-18

Other Useful Information.

18.1. Frequently Asked Questions and their Answers by Public Authority.

What are the key functions of the department :

The main function of the division is to executive the approved works for the specific year to the best satisfaction of department.

What is the Member of Parliament Local Area Development Scheme (MPLADS)?

No such funds available.

Are Panchayat at Functional in the District.

Not pertains to this division.

How many Panchayat Halqas are there in the District.

Not pertains to this division.

How many Blocks are there in the District.

Pertain to district administrate.

Chapter-7

A statement of boards, council, committees and other bodies constituted as its part.

The Board of Directors are the Governing body of the corporation, also there is cost Engineering Committee to deliver technical sanction for works.

. Chapter-8

Assistant Public Information Officer.

01	Name	Devindar Sing Behal
02	Designation	Executive Engineer
03	Contract No	941933849
04	Address	CPE JKSPDC Ladakh Region Kargil
05	Email- ID	Xenccdkargil1@gmail.com

Public Information Officer.

01	Name	I.A Karkroo
02	Designation	General Manager Civil.
03	Contract No	9419153731
04	Address	Corporate Office JKSPDC Srinagar/Jammu
05	Email- ID	-

Public Information Officer.

01	Name	Upinderjeer Sing
02	Designation	Director Finance.
03	Contract No	9419019026
04	Address	Corporate Office JKSPDC Srinagar/Jammu
05	Email- ID	-



**OFFICE OF THE EXECUTIVE ENGINEER CIVIL DIVISION-I
PDC KARGIL**

The Chief Project Engineer
PDC Ladakh Region Kargil

No: CD-I/PDC/K/
/03/2015

dated:

Subject: Information under section 4(1) (b) of J&K RTI Act, 2009.

Reference: Your No: CPE/PDC/K/157-78 dated: 28/02/2015.

Sir,

Kindly find the information sought with reference to above referred subject and reference.

Your faithfully

**Executive Engineer
Civil Division-I PDC
Kargil**